



SEISMIC ISOLATION APPLICATION: A HYBRID SYSTEM WITH CSS, LRB AND FVD

D. Kubin⁽¹⁾, J. Kubin⁽¹⁾, U. Ozcamur⁽²⁾, İ. A. Ilis⁽³⁾, G. Feroglu⁽⁴⁾, B. Elcik⁽¹⁾, K. Acarel⁽⁴⁾, M. Yalcin⁽⁴⁾

⁽¹⁾ Structural Engineer M. Sc., Prota Engineering Design and Consultancy Services Inc., dkubin@prota.com.tr

⁽¹⁾ Structural Engineer M. Sc., Prota Engineering Design and Consultancy Services Inc., jkubin@prota.com.tr

⁽²⁾ Structural Engineer M. Sc., TIS Technological Isolation Systems, ugurcan.ozcamur@tis.com.tr

⁽³⁾ Architecture M. Sc., Prota Engineering Design and Consultancy Services Inc., iailis@prota.com.tr

⁽⁴⁾ Structural Engineer, Prota Engineering Design and Consultancy Services Inc., goksenin.feroglu@prota.com.tr

⁽¹⁾ Structural Engineer M. Sc., Prota Engineering Design and Consultancy Services Inc., benguelcik@prota.com.tr

⁽⁴⁾ Structural Engineer, Prota Engineering Design and Consultancy Services Inc., kaan.acarel@prota.com.tr

⁽⁴⁾ Structural Engineer, Prota Engineering Design and Consultancy Services Inc., merve.yalcin@prota.com.tr

Abstract

The Data Center (DC) is a 5-storey reinforced concrete structure located in Marmara Region of Turkey consisting of two adjacent blocks, namely the Office and the Data Center Blocks. Both building blocks were designed using base isolation in order to ensure continuous operation following a major seismic event, and to protect non-structural components including high cost equipment. The base isolation system is composed of three types of devices: Lead rubber bearings at the office block (LRB), and curved surface sliders (CSS) coupled with fluid viscous dampers (FVD) at the Data Center block. A combined foundation system is designed under both building blocks separated by a seismic joint. The main challenge in the project is the necessity to employ the existing LRBS and FVDs that have already been purchased for a previous project, but never used. Therefore, it is decided that the existing LRB units to be utilized at the Office Block and FVD units coupled with the new FPS devices at the DC block. The LRB units have a displacement capacity of ± 650 mm. Using the existing stiffness properties and the seismic hazard data, ± 350 mm maximum displacement turned out to be sufficient for the design of the Office Block. On the other hand, despite the fact that DC block could have been designed for a similar displacement level, employing the FVD units in design may reduce this level substantially. However, another limitation was the ± 100 mm displacement capacity of the FVD units. Reducing the displacement magnitude to the level of ± 100 mm would not satisfy the base shear requirements, therefore two FVDs were serially connected to maintain ± 200 mm displacement level that also satisfies the base shear limitations. Two prototypes from all different device types were tested dynamically based on the EN15129 requirements at the Eucentre Laboratory in Pavia, Italy. FVD tests were performed on both individual and serially connected devices. A special test setup was used in order to perform the serially connected FVD units. All of the results have been evaluated and the structural performance targets have been confirmed.

Keywords: Base isolation; hybrid system; curved surface slider; lead rubber bearing; fluid viscous damper.

1. Introduction

The base isolation and energy dissipation systems have been widely accepted as the only viable technology that would control inter-story drift ratios and floor accelerations at the same time, especially for the civil engineering structures in the seismically active regions. Properly applied base isolation systems can protect both structural and nonstructural components in any structure and “continuous functionality” performance level can be achieved after a strong ground motion.

The main working principle of base isolation is summarized in Figure 1 [1]. Introducing a flexible layer beneath, natural period of the structure is increased, usually from 0.5-1.5 seconds to 2.5-3.5 seconds. By doing that, the accelerations that are affecting the structure are decreased significantly, resulting much lower base shear forces acting on the upper structure compared to a fixed base traditional solution. The illustration on an acceleration spectrum is shown in Figure 2. Another advantage of base isolation system is the fact that they induce extra energy dissipation during an earthquake, resulting in the reduction of the total impact of a strong ground motion on a structure. This behavior is also emphasized in Figure 2 [1]. Introducing additional damping systems with the base isolation devices further increases the damping effect and reduces the overall accelerations that have been imposed on the isolated superstructure. However, one shall also consider the fact that additional damping devices may increase the base shear forces on the superstructure and the horizontal force demands on the structural elements. Therefore, it is essential to find an optimum design solution between the base isolation devices and additional energy dissipation devices that are being used within the same system.

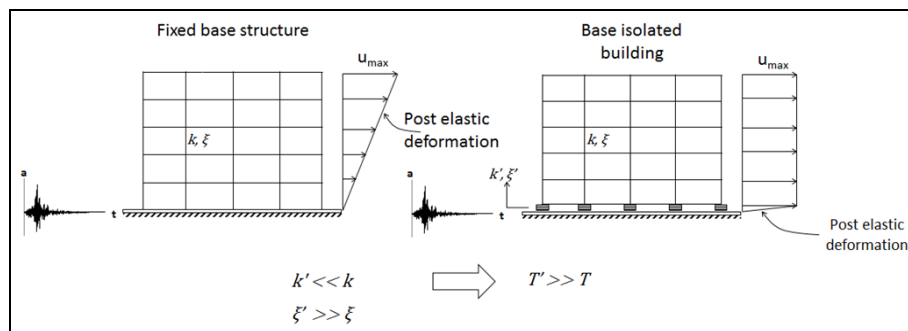

Fig 1: Comparison between general deformation patterns of base isolated and fixed base structures

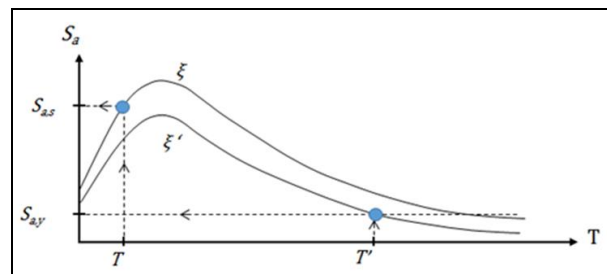

Fig 2: Effect of damping and period increase of base isolation systems on spectral acceleration values

This project is based on the application of the hybrid seismic base isolation system which includes curved surface sliders (CSS), lead rubber bearings (LRB) and fluid viscous dampers (FVD) at the same time because of the fact that LRBs and FVDs have already been purchased prior to the beginning of the project and it has been client’s requirement to design with the inclusion of these existing devices. This study focuses on the general properties of the isolated building, base isolation and energy dissipation devices, modelling, analyses, tests and on-site installation.

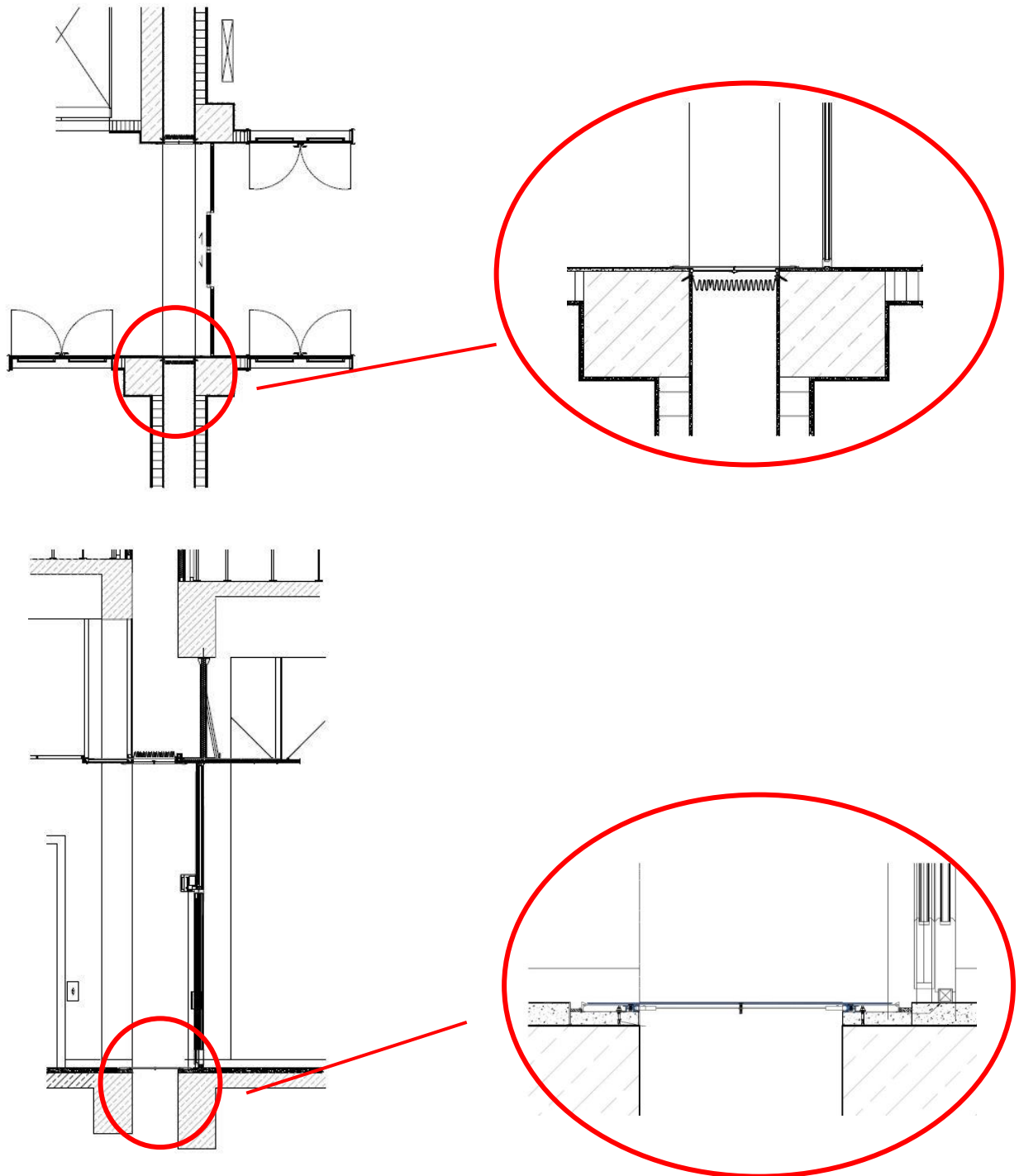

Fig 4: Detailed section view of the seismic gap between Office and DC Blocks [2]

The total seismic weights of Office Block and DC Block are calculated as 140.6 kN and 755.6 kN, respectively.

Office Block is supported by 20 LRB units; while, under DC block, 222 CSS coupled with 80 FVDs have been employed.

2.2 General Properties and Design of The Base Isolation System

The LRBs originally had a displacement capacity of ± 650 mm. Since they cannot be redesigned based on the site-specific seismic hazard requirements, the existing device properties are used to calculate linear and nonlinear properties. The general drawings of the LRB units are provided in Figure 5 [3]. According to the geometrical, dynamic and material properties of the existing units, the modelling properties are determined. For the sake of simplicity, the same parameters and values are used to model all 20 LRBs. The main parameters have been calculated as the following:

- Effective stiffness for DBE upper: 62850 kN/m
- Effective stiffness for MCE lower: 46200 kN/m

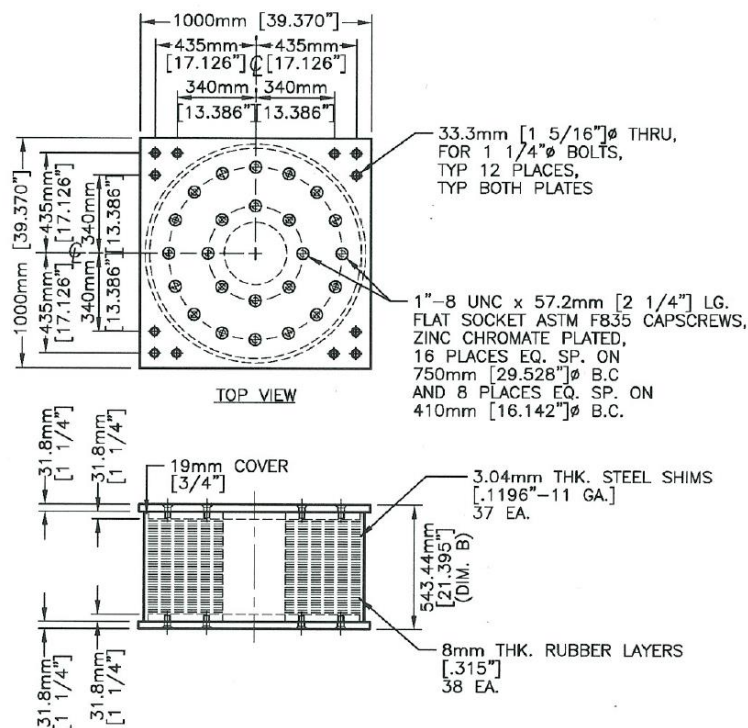

Fig 5: General drawings of LRBs used for the base isolation of Office Block [3]

The CSS and FVD units are coupled for the seismic isolation of DC Block. Being already purchased to be employed for a previous project the FVD units also were not specifically designed for this project. On the contrary, the main challenge of the design phase is to be able to satisfy the displacement limits of FVD while ensuring the correct seismic isolation of the DC Block. The existing FVD units had ± 100 mm displacement capacity, 750 kN load capacity with $C=1000$ kN*(sec/m) and $\alpha=0.4$. The general drawings of FVDs are provided in Figure 6 [4].

For each excitation direction, a total of 111 FVD units were employed to function together with the 222 CSS units. The general drawings of CSSs are provided in Figure 7 [5]. CSS units are the only seismic isolation devices that are designed specifically for this project. The design of CSS units is constrained by the fact that the FVD units are being coupled with them. As the displacement capacity of each FVD was ± 100 mm, the initial calculations have been performed to constrain the displacement demand with that of FVD units. However, due to the relatively high seismicity of the region and base shear limitations, ± 100 mm displacement demand was not achievable. Therefore, in order to solve this problem two FVD units were serially connected, to double the displacement capacity for maintaining ± 200 mm design requirement. CSS units are designed to satisfy this displacement limit while maintain the maximum base shear within the

acceptable performance threshold. Accordingly, the main modelling parameters of CSS units can be summarized as follows:

- Nominal, equivalent friction coefficient under average $G+0.3Q$ axial load: 6.39%
- Lower bound, equivalent friction coefficient under average $G+0.3Q$ axial load: 5.11%
- Upper bound, equivalent friction coefficient under average $G+0.3Q$ axial load: 8.69%
- Radius of curvature: 4950 mm

SPECIFICATIONS:

- 1.) UNIT TYPE: DOUBLE ACTING FLUID VISCOUS DAMPER.
- 2.) ALL PARTS THAT SLIDE RELATIVE TO ANY SEALS SHALL BE MADE FROM 17-4PH STAINLESS STEEL.
- 3.) APPROXIMATE WEIGHT OF THE UNIT = 400 LBS. [181 KG.]
- 4.) UNITS TO BE CONSTRUCTED FROM CORROSION PROTECTED MATERIALS.
- 5.) OPERATING FLUID IS INERT SILICONE, PER U.S.-FEDERAL STANDARD VV-D-1078.
- 6.) OPERATING AMBIENT TEMPERATURE RANGE: +32°F TO +120°F [0° TO 49°C] WITH MINIMAL CHANGE IN PERFORMANCE CHARACTERISTICS.
- 7.) DAMPER STROKE: ±4" (±100 mm), WITH IDENTICAL CHARACTERISTICS IN EITHER DIRECTION OF MOTION.
- 8.) DAMPING FORCE = 169 KIP. [750 kN].
- 9.) NOMINAL OUTPUT FUNCTION: $F = CV^\alpha$

$$C = 1000 \text{ kN}^2(\text{sec}/\text{m}) \quad \alpha = 0.4$$

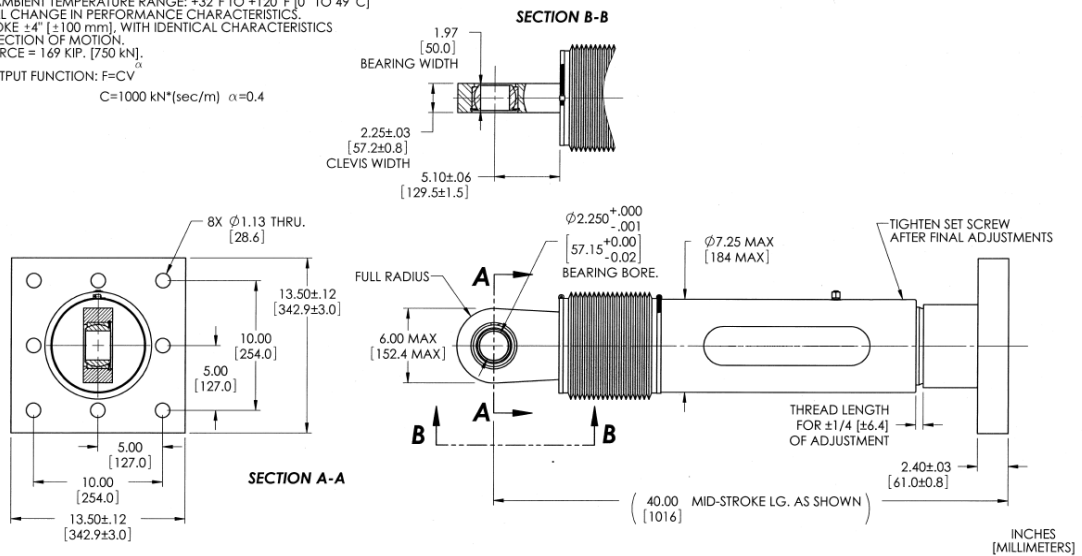

Fig 6: General drawings of FVDs used for the base isolation of DC Block [4]

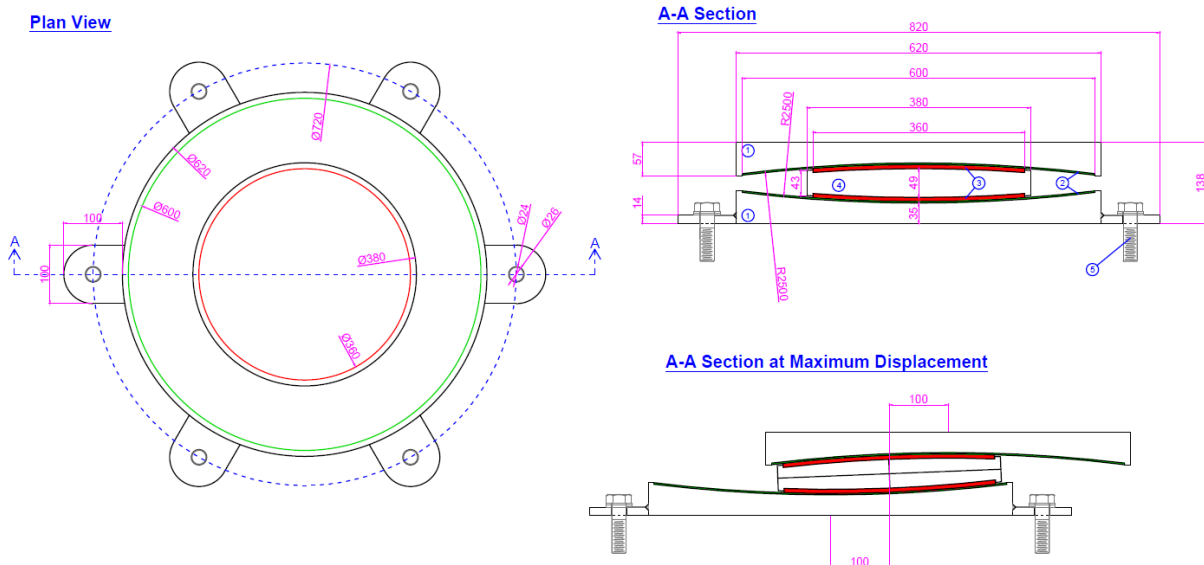

Fig 7: General drawings of CSSs used for the base isolation of DC Block [5]

2.3 General Properties of The Site

The seismicity of the site is determined by a site-specific probabilistic seismic hazard assessment. The resulting acceleration spectra for both DBE and MCE levels are provided in Figure 8 [6]. The site-specific spectra are also compared with the regional earthquake map and confirmed that site-specific acceleration values are higher than the officially published hazard map of the region. After this, in order to be able to use during nonlinear response history analyses (NRHA), 7 pairs of ground motions have been selected and matched to these acceleration spectra.

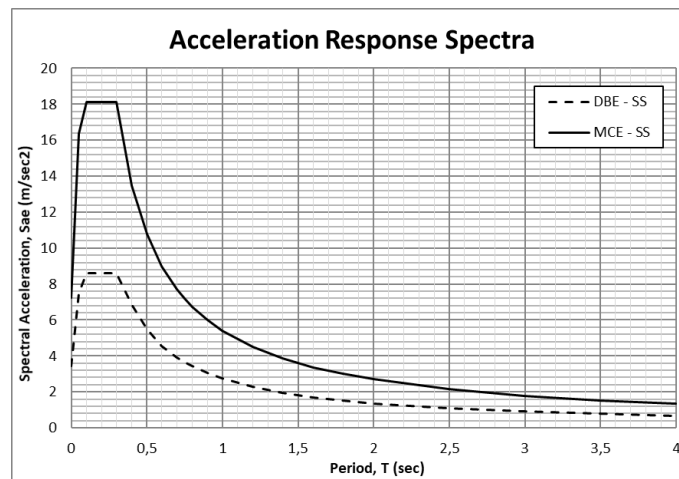

Fig 8: Site-specific acceleration spectra at the construction site [6]

3. Structural Analyses

Linear and nonlinear analyses have been carried out for the entire building as both of the Office and DC Blocks are modelled on the common rigid foundation system. All of the structural analyses are performed using SAP2000 [V20] and ProtaStructure 2018 computer programs [4.0 SP5]. The results of linear and nonlinear analyses have been summarized in Table 1. This table is prepared considering the maximum demands from linear analyses and the average of 7 from the NRHA.

Table 1: Results of structural analyses

	Office Block (LRB)	DC Block (CSS+FVD)
Linear Analyses		
Base Shear Demand (DBE)	0.105W	0.098W
Displacement Demand (MCE)	±344 mm	±193 mm
Nonlinear Analyses		
Base Shear Demand (DBE)	0.098W	0.090W
Displacement Demand (MCE)	±320 mm	±180 mm

Based on the results obtained by structural analyses it has been concluded that the existing LRB units satisfies the displacement and stiffness requirements of the Office Block. Based on the analyses using

generic isolation units, it was determined that the 100 mm displacement limit cannot satisfy the maximum base shear requirements. Therefore, the design is based on 193 mm target displacement using MCE loading that also satisfies acceptable base shear ratio under DBE. Consequently, CSS units were designed based on ± 200 mm displacement capacity. In order to couple these units with existing FVD units, having ± 100 mm displacement capacity, two of them were serially connected to reach ± 200 mm capacity.

4. Serially Connected Fluid Viscous Dampers (FVD)

Two FVD units are bolt-connected back to back in order to increase their total displacement capacity to ± 200 mm as explained above. The serially connected coupled devices are then anchored to columns at one end and beams at the other end. Additional ball bearing type steel connections have also been employed to ensure that the coupled FVDs would be free to move in all possible directions during a seismic event. The initial drawings and the test setup of the coupled FVD units are provided in Figure 9 and the final on-site assembly is shown in Figure 10.

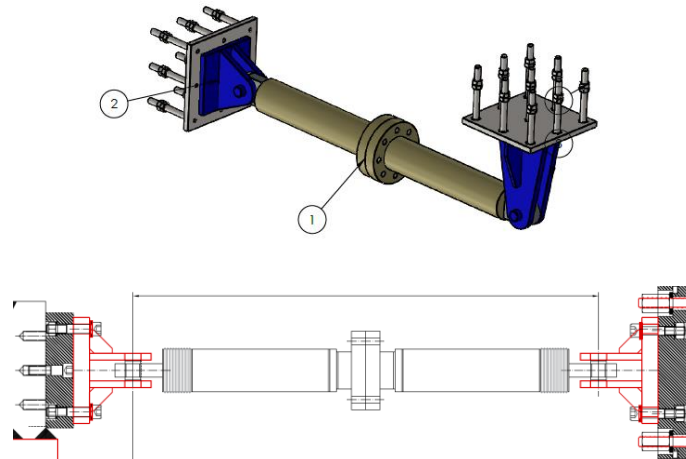

Fig 9: Initial drawing (top) and drawing of the test setup (bottom) of the coupled FVDs



Fig 10: Final on-site assembly of the coupled FVDs

5. Test Results

Prototype testing of all the devices have been performed in Eucentre Laboratory in Pavia, Italy. Two prototypes from each different device type have been subjected to testing procedures defined in the relevant sections of EN15129. The results of prototype tests are summarized and discussed in this section of this study.

5.1 Lead Rubber Bearings

The estimated effective stiffness and the overall damping values are matched with the prototype test results, considering upper bound and lower bound coefficients, as well. One hysteresis loop from a dynamic test with ± 360 mm horizontal displacement, 0.6 m/sec horizontal velocity and 7000 kN axial load is provided in Figure 11 [7]. Average effective stiffness of the three cycles are determined to be 2933 kN/m and the average damping ratio is calculated as 40.7%, both of which are consistent with the as built parameters. Additionally, vertical parameters are also evaluated separately which are in compliance with the expected values and therefore the performance of the LRBs are approved.

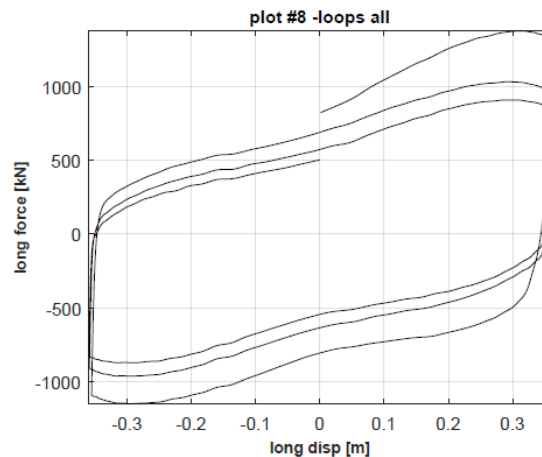

Fig 11: An example hysteresis loop from one of the dynamic tests on LRB prototypes performed in Eucentre Laboratory [7]

5.2 Curved Surface Sliders

During the prototype tests of both types of CSS units, the estimated friction coefficient values, which is considered as the most essential characteristic of any curved surface sliders are also in compliance with the design parameters. Single hysteresis loop from a dynamic test with ± 200 mm horizontal displacement, 0.4 m/sec horizontal velocity and 4800 kN axial load is provided in Figure 12 [8]. Average friction coefficient value from all cycles of all of the tests that have been performed under same average $G+0.3Q$ axial load is determined to be 6.29%, which can in compliance with the design value of 6.39%. Based on the measured post-yield stiffness, effective stiffness and maximum horizontal force values, CSS units are approved as well.

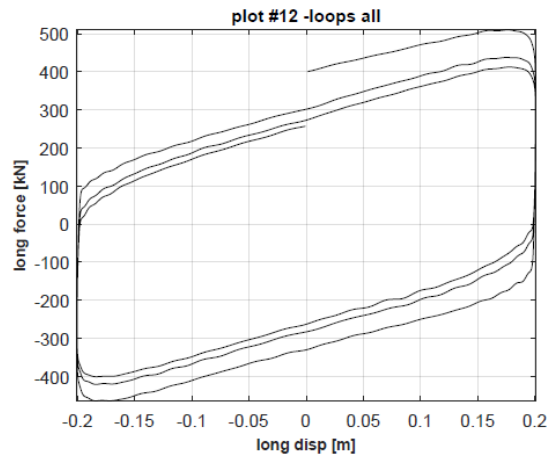

Fig 12: An example hysteresis loop from one of the dynamic tests on CSS prototypes performed in Eucentre Laboratory [8]

5.3 Fluid Viscous Dampers

FVD tests have been performed on a single and also on serially connected devices separately. It is observed that the coupled FVD units perform as expected. When two dampers are coupled, the maximum displacement of ± 200 mm can be reached without inducing any excessive force or any damage on the system. It is also observed that the hysteresis of coupled system is very consistent. A sample dynamic test is chosen, and hysteresis loops of that procedure applied on both single and coupled FVDs are shown in Figure 13 [9]. The presented tests on the single FVD is performed with ± 90 mm displacement and 0.4 m/sec velocity; whereas, coupled FVD system is subjected to ± 190 mm displacement and 0.4 m/sec velocity in the prototype tests. A snapshot taken during the tests is shown in Figure 14.

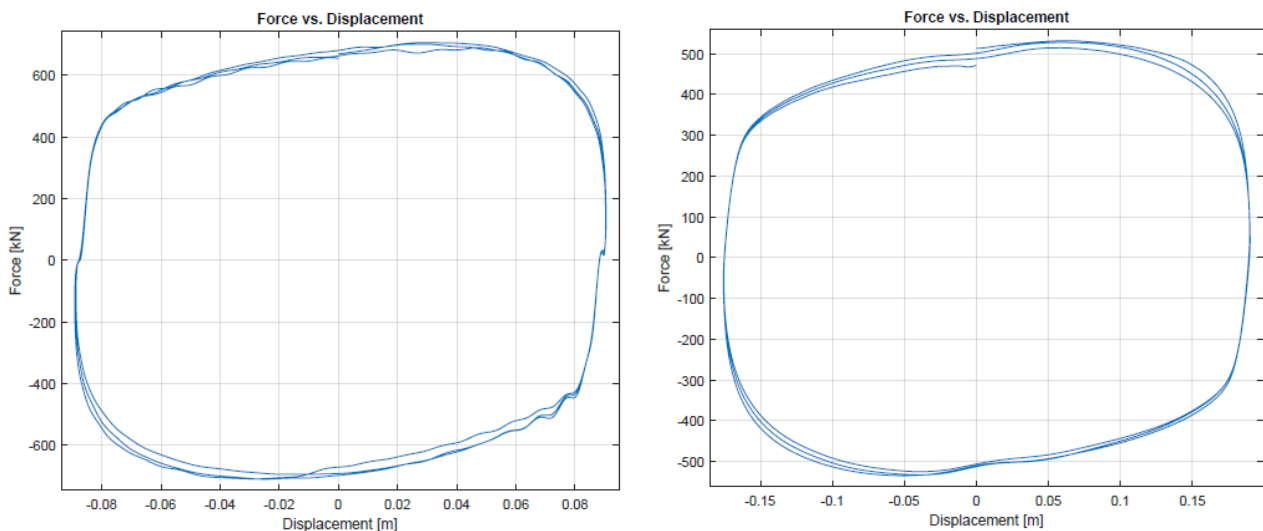

Fig 13: An example hysteresis loops from one of the dynamic tests on single (top) and coupled (bottom) prototype FVDs performed in Eucentre Laboratory [9]

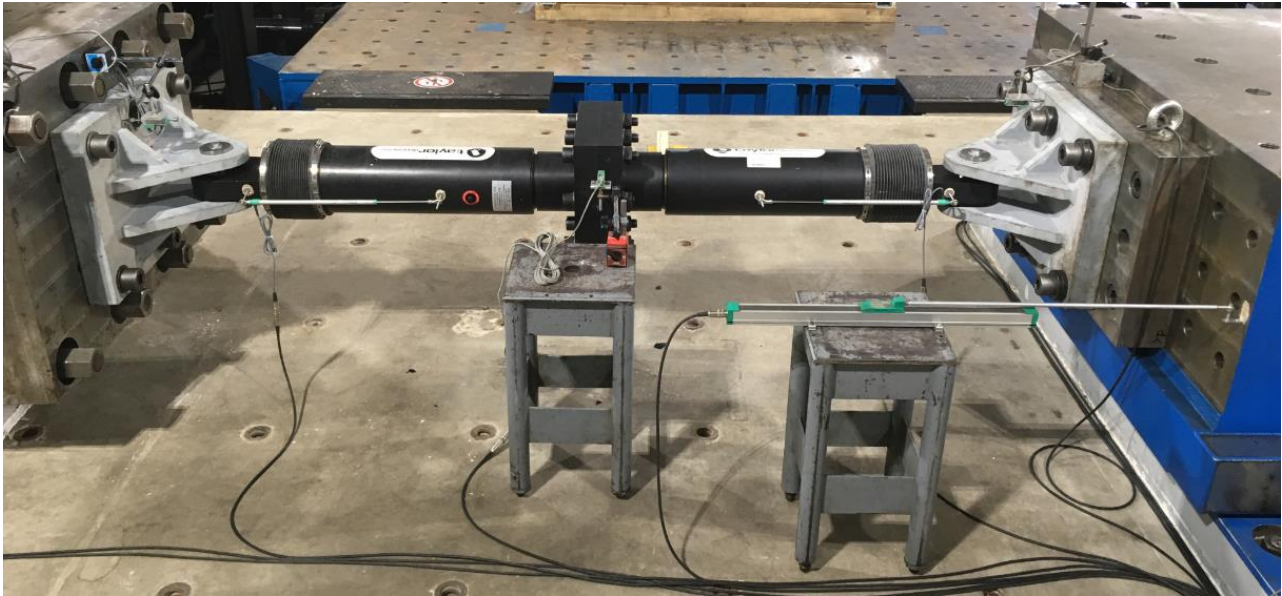

Fig 14: Coupled FVD test setup in Eucentre Laboratory

6. Conclusion

This study is based on the application of the hybrid seismic base isolation system which includes curved surface sliders (CSS), lead rubber bearings (LRB) and fluid viscous dampers (FVD) on a 5-storey R/C Office and Data Structure building on a combined raft foundation. Both building blocks are designed using base isolation in order to ensure continuous operation following a possible major seismic activity.

It is decided that the existing LRB units to be utilized at the Office Block and FVD units coupled with the new FPS devices at the DC block.

The existing LRB units have been modelled and non-linear time history analyses confirmed that they would comply with the specifications and performance targets of the office block. For DC Block, it was not possible to reduce the displacement demand on the base isolation devices to comply with the actual displacement capacity of the existing FVD units. For that reason, two FVD units were serially connected to increase the displacement capacity to ± 200 mm. By this approach, the base shear requirements and displacement limitations are satisfied simultaneously.

Two prototypes from all different device types were tested dynamically based on the EN15129 requirements at the Eucentre Laboratory in Pavia, Italy. FVD tests were performed on both individual and serially connected devices. A special test setup was used in order to perform the serially connected FVD units. A similar setup is also prepared for coupled FVD system on-site. All of the prototype test results have been evaluated and it is observed that the test results in compliance with the requirements of EN15129. Technical specifications and modelling parameters that have been used during the previously performed NRHA, and all of the structural performance targets have been confirmed.

7. Acknowledgement

We would like to express our special thanks to Prota Design Center for their contributions.



8. References

- [1] Sucuoğlu, H., & Akkar, S. (2014). *Basic Earthquake Engineering - From Seismology to Analysis and Design*. Springer International Publishing.
- [2] Prota Engineering (2018). *Technical Specifications: isolator-damper layouts*.
- [3] Dynamic Isolation Systems (2014). *Drawing No: 264-100: LRB 950 Type A Isolator*.
- [4] Taylor Devices Inc. (2015). *Fluid Viscous Damper Technical Manual: 67DP-19189-01*.
- [5] TIS Technological Isolation Systems (2018). *Technical Drawing Type 1 and 2 CSS for Project 00815*.
- [6] TIS Technological Isolation Systems (2018). *Technical Report ST_A03_R03-1806204*.
- [7] Eucentre Laboratory (2019). *Technical Report EUC109/2018E: Characterization Tests on Type A 264-100 Devices*.
- [8] Eucentre Laboratory (2019). *Technical Report EUC110/2018E: Characterization Tests on TDP11600/200/5 Devices*.
- [9] Eucentre Laboratory (2019). *Technical Report EUC113/2018E: Characterization Tests on FVD 750 kN Devices*.